



Installation and Quick Start

ReadyNAS

RR4360S

RR4360X

NETGEAR®

Contents

Package Contents	3
Prepare the Installation Site.....	3
Install the System in a Rack	4
Precautions.....	4
Rack Installation	5
Install Cable Management.....	6
Install Disks	7
Basic Setup.....	9
Reformat Disks.....	10
Additional Information	11

Package Contents

Important: Read all safety warnings in the hardware manual for your system before connecting the system to the power supply.

Your package contains the following items:

- RR4360 chassis including 60 disk trays
- Rack mount rail kit
- Cable management kit
- Ten Power cords. (Five sets of two power cords for the two supplied power supplies. Each set for a different region.)
- Ethernet cable
- 60 screws to optionally screw the disk trays to the disks

Prepare the Installation Site

Keep the following considerations in mind as you install your unit:

- **Ambient operating temperature.** If the unit is installed in a closed or multi-unit rack assembly, the ambient operating temperature of the rack environment might be greater than the ambient temperature of the room. Therefore, consider installing the equipment in an environment compatible with the maximum rated ambient temperature.
- **Reduced airflow.** Mount the equipment into a rack so that the amount of airflow required for safe operation is not compromised.
- **Mechanical loading.** Mount the equipment into a rack so that a hazardous condition does not arise due to uneven mechanical loading.
- **Circuit overloading.** Consider the equipment's connection to the power supply circuitry and the effect of possible overloading of circuits on overcurrent protection and power supply wiring. Consider equipment nameplate ratings when addressing this concern.
- **Reliable ground.** This product requires that a reliable ground be maintained at all times. To ensure this, ground the rack itself. Pay particular attention to power supply connections other than the direct connections to the branch circuit (for example, the use of power strips).
- **Setup location.** This product is intended for installation in a restricted access location (dedicated equipment rooms, service closets, and the like) only.
- **Front clearance.** Leave enough clearance in front of the rack (about 64 cm or 25 inches) to enable you to open the front door completely and in the back of the rack (about 76 cm or 30 inches) to allow for sufficient airflow and ease in servicing.
- **Rear rack clearance.** This product requires nearly the full depth of the rack. Placement of items such as a power strip inside the rack might block the product from being completely pushed in.

Install the System in a Rack

Use the rack-mount hardware included with your ReadyNAS or your expansion disk array to install it in a rack.

Note that the left and right rails are not identical. The left rail is marked with a sticker bearing the letter L, and the right rail is marked with a sticker bearing the letter R. Each rail has an outer rail, a middle rail, and an inner rail. Do not exchange the inner rails of the left and right rails.

While installing the system into a rack, keep the ball bearing shuttle locked at the front of the middle rail.

A minimum of two people are required for safe installation of the system.

DANGER: A unit with installed drives can weigh more than 34 kg (75 pounds). To avoid injury or damage to the equipment, perform the rack-mount installation with appropriate assistance. We recommend installing the system into the rack before installing the disks.

Precautions

Follow these rack-mount precautions:

- Ensure that the leveling jacks on the bottom of the rack are fully extended to the floor with the full weight of the rack resting on them.
- In single-rack installations, attach stabilizers to the rack. In multiple-rack installations, couple the racks together.
- Always make sure the rack is stable before extending a component from the rack.
- Extend only one component at a time. Extending two or more simultaneously might cause the rack to become unstable.
- Review the electrical and general safety precautions that came with the components you are adding to your chassis.
- Determine the placement of each component in the rack before you install the rails.
- Install the heaviest components on the bottom of the rack first, and then work up.
- Use a regulating uninterruptible power supply (UPS) to protect the ReadyNAS from power surges and voltage spikes and to keep your system operating in case of a power failure.
- Allow any hot-plug drives and power supply modules to cool before touching them.
- Always keep the rack's front door and all panels and components on the servers closed when not servicing them to maintain proper cooling.

Rack Installation

Read these instructions in their entirety before you begin.

Note: The rail ends require square holes in the rack. You cannot install the supplied rails using threaded rail holes.

➤ To install the system into a rack:

1. Using the left rail, pull the inner rail out of the outer rail until it is fully extended.
The middle and outer rail might lock in the extended position.
2. Press the locking tab down to release the inner rail and separate it from the outer and middle rails.
3. Align the hooks on the chassis with the holes in the inner rail and press them together.
4. Slide the rail forward until it locks on to the chassis.
5. Repeat steps 1 through 4 using the right rail.
6. If the middle and outer rails are locked on either of the rails, press the locking tab to release, and slide the middle rail into the outer rail.
7. Working with the left rail and left side of the chassis, insert the hooks in the front surface of the outer rail into holes in the front of the rack and press the rail down to fasten it to the rack.
8. Repeat with the right rail and right side of the chassis.
9. Working with the left and right rails, shorten or extend the outer rail as necessary to insert the hooks in the back surface of the outer rail into holes in the back of the rack and press the rail down to fasten it to the rack.
10. Secure the rails with one screw through the front and rear of each rail.
11. On both rails, pull the middle rail forward until it locks.
12. Lock the shuttle on the middle rail at the front of the middle rail.
13. Make sure that the ReadyNAS chassis is oriented right side up.
14. Using two people, align the inner rails on the chassis with the middle rails and then, pushing evenly on both sides, push the inner rail into the middle rail and ball bearing shuttle until both sides lock into the rail in a fully extended position.
15. Simultaneously, depress the locking tabs on both sides of the chassis and push it evenly all the way into the rack.

Install Cable Management

The cable management hardware folds when the unit is pushed toward the back of the rack, and straightens as the unit moves forward. If you attach the cables to the cable management hardware, the cables also fold or straighten as the unit is moved in the rack, which eliminates the tugging by the cables on the connectors on the unit.

The cable management kit consists of the cable management arm assembly with attached chassis bracket and rack bracket, and the parts kit.

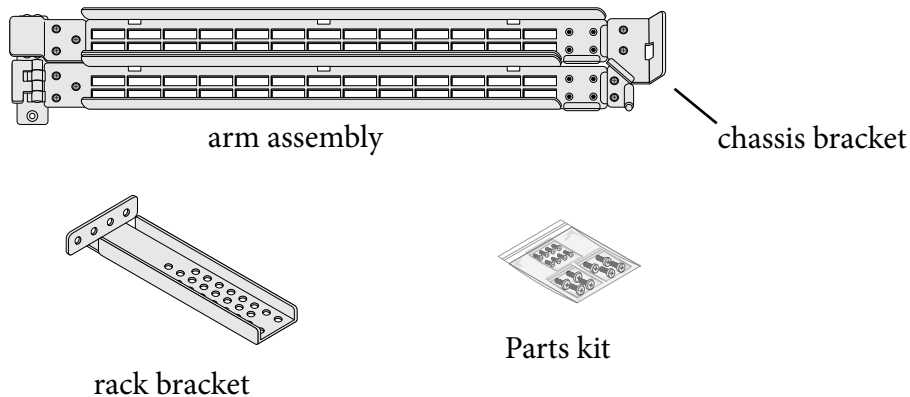

➤ To install the cable management hardware:

1. Attach the rack bracket to the arm assembly using three bolts.
2. Attach the chassis bracket to the bracket on the left rear of the RR4360 chassis using two bolts.
3. Attach the rack bracket to the left rear post of the rack using two bolts. Align the rack bracket so that the lower bolt is 9 rack positions above the rail attachments.

On some racks, a screw driver with a shaft longer than the rack bracket can make this step easier. Alternatively, you can place the bracket on the outside of the rack rail and a second person can drive the screws from inside the rack.

After fully cabling the ReadyNAS server, use cable ties to attach the cables to the arm assembly.

Install Disks

Install at least one, and up to 60, disks before powering on your ReadyNAS for the first time.

If you install previously formatted disks, you must use your ReadyNAS to reformat them the first time you power on the system. For information about reformatting disks, see *Reformat Disks* on page 10.

Note: Reformatting disks deletes all data on the disks.

When you power on your system for the first time or if you reset your system to its factory default settings, the optimal RAID mode and level are automatically selected for you based on the number of disks that are installed. If desired, you can later change the RAID settings manually. For information about RAID settings, including changing RAID settings, see the *ReadyNAS OS 6 Software User Manual*. A link to this manual is available at www.netgear.com/support/product/ReadyNAS_OS_6 or through a link in the product's user interface.

➤ To install your disks:

1. Pull the chassis forward so that panel on the top front of the chassis is clear of the rack.
2. Press the front pair of release buttons on the sides of the chassis and push the top cover toward the front until you can lift it off.

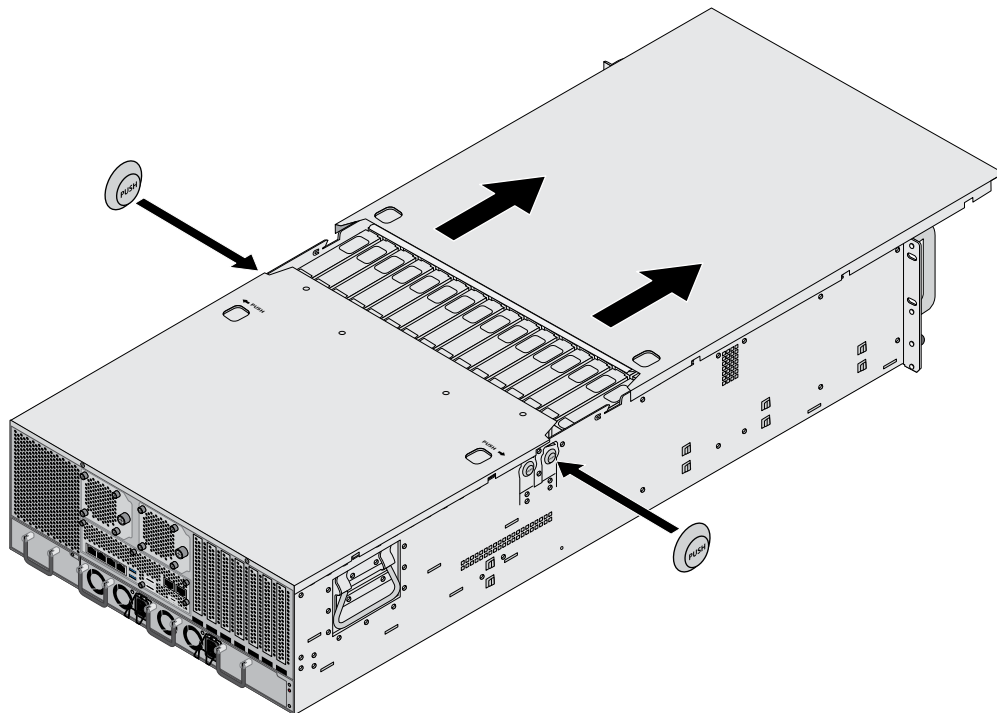

3. Insert your drives into the tool-less disk brackets supplied with the RR4360 server to hold your disks in the server.

The figure shows the bracket tabs that align with the mounting holes in your drive.

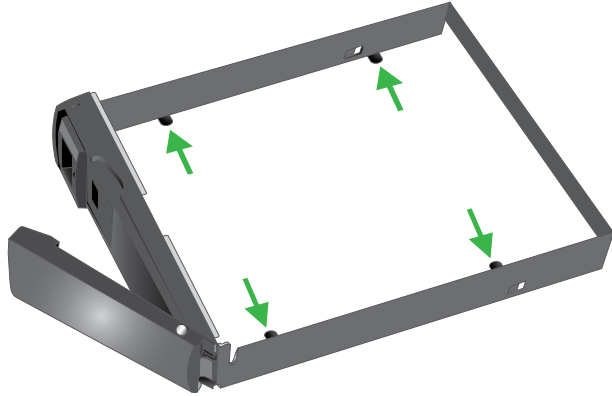

Note: The following figure illustrates how disk numbers are assigned based on their position in the chassis.

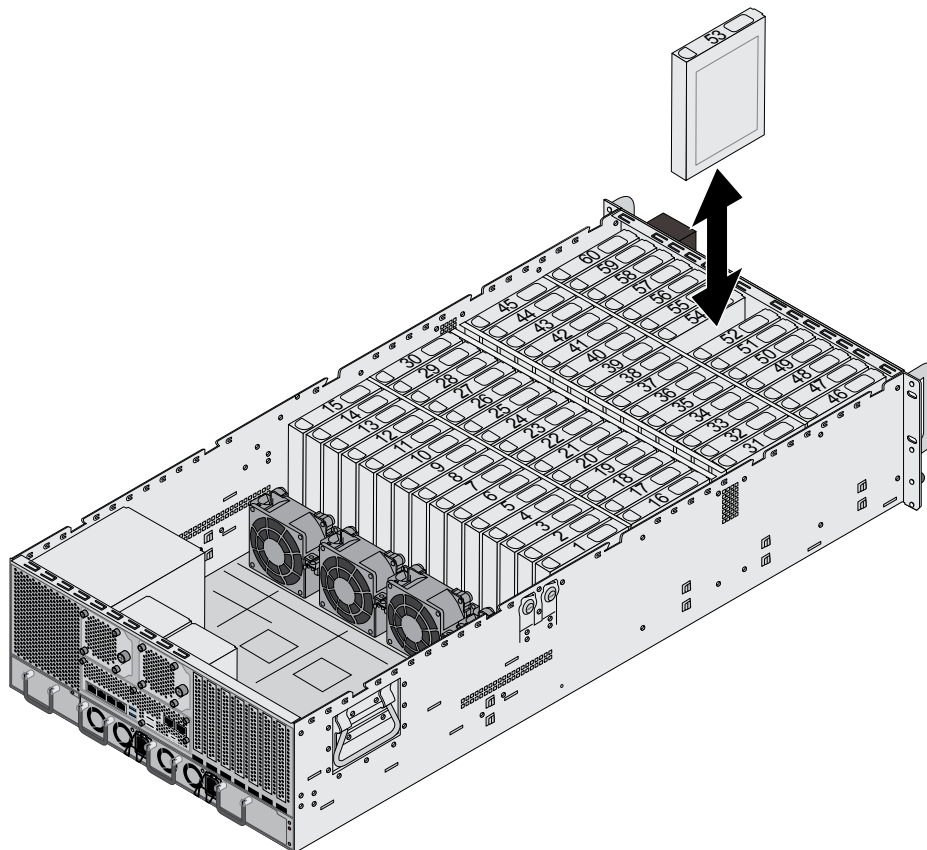

When you reinsert the drive and tray into a slot, the weight of the drive seats the drive.

Basic Setup

After you follow these instructions, your ReadyNAS is ready to use in a production environment. Setup takes approximately 15 minutes.

➤ To set up your storage system:

1. Install all available disks that you want to use in your ReadyNAS system.

Note: If you are using previously formatted disks that contain data, you must reformat these disks before continuing. See *Reformat Disks* on page 8.

For a list of supported disks, see the Hardware Compatibility List at netgear.com/readynas-hcl.

For information about installing disks, see the hardware manual for your system or visit www.youtube.com/watch?v=hLiu0VeXd-Y.

2. Place your system in a location that provides adequate ventilation.
High-capacity disks can produce considerable heat. It is important to ensure that the fan exhausts are unobstructed. For a complete list of placement considerations, see the hardware manual for your system.
3. Connect a power cord to each power supply and plug the power cords into a wall outlet or power strip.

Note: RR4360 systems require at least two power supplies.

4. Use an Ethernet cable to connect an Ethernet port on the storage system to your network.
5. If necessary, press the **Power** button to turn on the system.
6. Wait for the Power LED to turn solid blue.
7. Visit www.netgear.com/raidar to download and install the NETGEAR RAIDar utility.
Download RAIDar to a computer connected to the Internet and transfer the downloaded file to the computer on the same LAN as your ReadyNAS system.
8. Start RAIDar.
RAIDar scans your local broadcast domain for your ReadyNAS. The broadcast domain is your local network plus any networks reachable through a switch or repeater, but not through a router.
9. Select your ReadyNAS in the RAIDar window.
10. Click the **Setup** button.

Note: Depending on your browser settings, you might get a message such as "This Connection is Untrusted." Select the options to continue connecting.

The Authentication Required window opens.

11. Log in to your ReadyNAS.
Enter **admin** for the user name, enter **password** for the password, and click the **OK** button.

The ReadyNAS local admin page displays in your browser and launches a setup wizard.

12. Follow the prompts of the setup wizard to configure your ReadyNAS system.

The setup process is complete. You can begin using your ReadyNAS storage system.

Reformat Disks

If you are using previously formatted disks that contain data, you must reformat the disks before you can use them with your ReadyNAS system.

WARNING: This process erases all data and reformats all disks into a single RAID volume. If you want to preserve the data on the disks, you must back up the data to an external drive before using the disks in your ReadyNAS storage system.

➤ To reformat previously formatted disks:

1. If your system is powered on, gracefully power off the system.
See *Additional Information* on page 10.
2. Install the previously formatted disks.
For a list of supported disks, see the Hardware Compatibility List at kb.netgear.com/app/answers/detail/a_id/20641.
For information about installing disks, see the hardware manual for your system.
3. Press and hold the **Reset** button.
4. Press the **Power** button.
The system powers on.
5. Continue pressing the **Reset** button for about five seconds until the system enters the boot menu, and then release it:
The front panel lights LED 1, LED 2, and LED 3 blink.
6. Press and hold the **Reset** button for about one second, and then release to scroll to the next boot mode menu item.
7. Repeat the press, hold, and release of the Reset button until LED 2 is lit, and LED 1 and LED 3 are off.
8. Press and hold the **Reset** button for about four seconds to initiate a factory reset.
The system initiates a short disk test that takes 2 to 5 minutes.
Then, a 10-minute time-out period begins. After 10 minutes, the factory default process starts.
The system returns to its factory default settings and reformats all installed disks for use with ReadyNAS OS 6.

When the factory default process is complete, the reformatted disks are ready to use with your system.

Additional Information

To help keep your storage system healthy and prevent the risk of data loss, follow these rules of usage:

- Never replace more than one disk at a time while the system is powered on.
- If you must power off your system, power it off gracefully, when possible.

➤ **To gracefully power off your storage system:**

1. Press the **Power** button on the front panel of the system.
The Power LED blinks, prompting you to confirm the shutdown.
2. Press the **Power** button again.
The system shuts down gracefully.

For more information about setting up, configuring, and using your system, see the software and hardware manuals for your system. Links to these manuals are available at www.netgear.com/support/product/ReadyNAS_OS_6 or through a link in the product's user interface.

Support

Thank you for purchasing this NETGEAR product. You can visit www.netgear.com/support to register your product, get help, access the latest downloads and user manuals, and join our community. We recommend that you use only official NETGEAR support resources.

Trademarks

© NETGEAR, Inc., NETGEAR and the NETGEAR Logo are trademarks of NETGEAR, Inc. Any non-NETGEAR trademarks are used for reference purposes only.

Compliance

For the current EU Declaration of Conformity, visit:
http://kb.netgear.com/app/answers/detail/a_id/11621.

For regulatory compliance information, visit:
<http://www.netgear.com/about/regulatory/>.

See the regulatory compliance document before connecting the power supply.

 **NETGEAR INTL LTD**
Building 3, University Technology Centre
Curraheen Road, Cork, Ireland



201-21283-03
April 2017

NETGEAR, Inc.
350 East Plumeria Drive
San Jose, CA 95134, USA