

Installation Guide

48-Port Gigabit Ethernet Unmanaged PoE+ Switch with 24-Port PoE+ (380W) Model GS348PP



Package contents

- Switch model GS348PP
- Power cord (varies by region)
- Rack-mount kit with four rubber feet
- Installation guide

Note: We recommend that you use Category 5e (Cat 5e) cable or higher for Gigabit Ethernet connections.

1. Register with the NETGEAR Insight app

1. Search for **NETGEAR Insight** and download the latest app.



2. Set up a NETGEAR account if you do not have one.
3. Tap the menu in the upper-left corner.
4. Tap **REGISTER ANY NETGEAR DEVICE**.
5. Enter the serial number located on the bottom of the switch, or use the camera on your mobile device to scan the serial number bar code.
6. Tap **GO**.

The switch is registered and added to your account. You can now view the switch in the NETGEAR Insight app.

Note: Because this is an unmanaged switch, you cannot configure or manage it in NETGEAR Insight.

2. Connect the switch

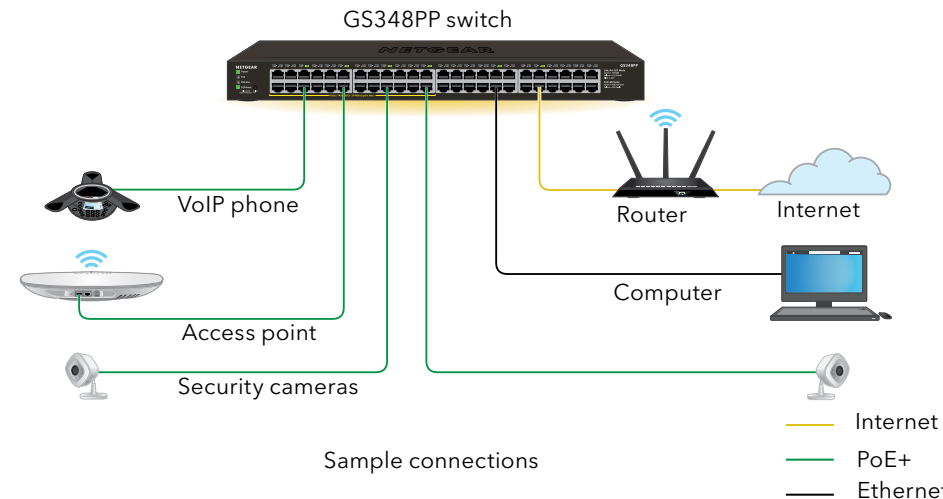

3. Check the LEDs

When you connect the power cord to the switch and plug it into an electrical outlet, the LEDs indicate the status.

The GS348PP provides PoE+ or PoE power on ports 1-24 up to 30W to each port, with a PoE power budget of 380W across all active PoE ports.

LED	Description
Power	On. The switch is receiving power. Off. The switch is not receiving power.
Ethernet (RJ Port in Link/ACT Mode)	Green. 1000 Mbps link on this port. Blinking. 1000 Mbps activity on this port. Yellow. 100 Mbps or 10 Mbps link on this port. Blinking. 100 Mbps or 10 Mbps activity on this port. Off. No link is detected on this port.
PoE+ (RJ Port in PoE Mode)	Green. PoE+ is in use. Yellow. PoE+ halted. Off. PoE+ is not in use on this port.
Fan	On. There is a fan error. Off. The fan is working correctly.
PoE Max	Indicates the status of the switch's PoE budget: Off. Sufficient. More than 7W of PoE power is available. On. Less than 7W of PoE power is available. Blinking. At least once during the previous two minutes, less than 7W of PoE power was available.
LED Mode	Green. Port is in Link/Act Mode. Yellow. Port is in PoE Mode.

NETGEAR, Inc.
350 East Plumeria Drive
San Jose, CA 95134, USA

NETGEAR INTERNATIONAL LTD
Floor 1, Building 3,
University Technology Centre
Curraheen Road, Cork,
T12EF21, Ireland

PoE considerations

The PoE and PoE+ power supplied by the switch is prioritized in ascending port order: Ports 1-24 support PoE and PoE+ with a total power budget of 380W.

If the power requirements for the attached powered devices (PDs) exceed the total power budget of the switch, the PD on the highest-numbered port is disabled to make sure that the PDs connected to the higher-priority, lower-numbered ports are supported first.

A PD listed as an 802.3at PoE powered device does not necessarily require the maximum power limit of the specification. Many PDs require less power, potentially allowing more PoE ports to be active simultaneously.

The following table shows the standard power ranges calculated with the maximum cable length of 328 feet (100 meters).

Device Class	Standard	Class Description	Power Reserved by the Device	Power Delivered to the Device
0	PoE and PoE+	Default power (full)	0.44W	0.44W-12.95W
1	PoE and PoE+	Very low power	4.0W	0.44W-3.84W
2	PoE and PoE+	Low power	7.0W	3.84W-6.49W
3	PoE and PoE+	Mid power	15.4W	6.49W-12.95W
4	PoE+ only	High power	30.0W	12.95W-25.5W

If a device receives insufficient PoE power from the switch, consider using a shorter cable.

PoE Troubleshooting

Here are some tips for correcting PoE problems that might occur:

- If the PoE Max LED is solid yellow, disconnect one or more PoE devices to prevent PoE oversubscription.
- For each powered device (PD) that is connected to the switch, the associated PoE LED on the switch lights solid green. If the PoE LED lights solid yellow, a PoE fault occurred and PoE halted because of one of the conditions listed in the following table.

PoE Fault Condition	Possible Solution
A PoE-related short circuit occurred on the port.	The problem is most likely with the attached PD. Check the condition of the PD, or restart the PD by disconnecting and reconnecting the PD.
The PoE power demand of the PD exceeded the maximum level that the switch permits. The maximum level is 15.4 for a PoE connection or 30W for a PoE+ connection	
The PoE current on the port exceeded the classification limit of the PD.	
The PoE voltage of the port is outside the range that the switch permits	Restart the switch to see if the condition resolves itself.

Mount the switch in a rack

We recommend that you use the brackets and screws that came with the switch.

1. Attach the mounting brackets to the side of the switch.
2. Insert the screws through each bracket and into the bracket mounting holes in the switch.
3. Tighten the screws with a No. 1 Phillips screwdriver to secure each bracket.
4. Align the mounting holes in the brackets with the holes in the rack, and insert two pan-head screws with nylon washers through each bracket and into the rack.
5. Tighten the screws with a No. 2 Phillips screwdriver to secure mounting brackets to the rack.

Support

Thank you for purchasing this NETGEAR product. You can visit <https://www.netgear.com/support/> to register your product, get help, access the latest downloads and user manuals, and join our community. We recommend that you use only official NETGEAR support resources.

Si ce produit est vendu au Canada, vous pouvez accéder à ce document en français canadien à <https://www.netgear.com/support/download/>. (If this product is sold in Canada, you can access this document in Canadian French at <https://www.netgear.com/support/download/>.)

IMPORTANT

For regulatory compliance information including the EU Declaration of Conformity, visit <https://www.netgear.com/about/regulatory/>.

See the regulatory compliance document before connecting the power supply.

Do not use this device outdoors. The PoE source is intended for intra building connection only.

Specifications

Specification	Description
Network interfaces	48 Gigabit Ethernet RJ-45 ports that support 1G, 100 M, and 10 M 24 PoE/PoE+ ports
Power input	100-240VAC, 8A max
Max PoE budget	380W
Dimensions (W x D x H)	17.3 x 12.2 x 1.7 in. (440 x 310 x 43 mm)
Weight	10.1 lb (4.56 kg)
Operating temperature	32-113°F (0-45°C)
Operating humidity	10%-90% relative humidity, noncondensing
Compliance	FCC class A, CB, CE class A, VCCI class A, RCM class A, KC, BSMI

